

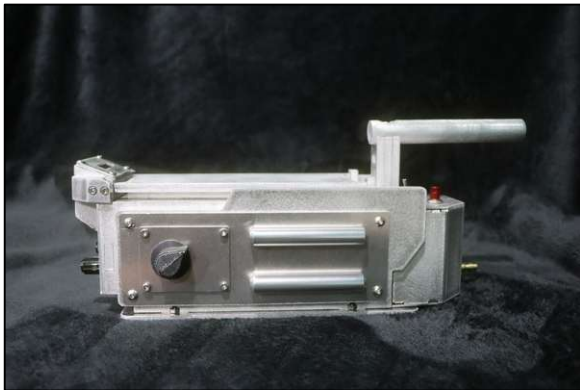

**Ghostbusters Ghost Trap
(Fixed Body Version)
April 2026**

*Design: Mark Hammonds
Instructions: Jeff Dennison*



Contents

DETAILS (Send Cut Sent Description):	3
PARTS (Base Kit, Dog Ears, and Axles)	4
HARDWARE	6
ADDITIONAL PARTS	7
CONSTRUCTION MATERIALS	9
TOOLS	9
DECALS	10
ELECTRONICS	10
BUILD INSTRUCTIONS	11
Part 1: Assemble Segmented LED Box	11
Part 2: Assemble Handle Mount	14
Part 3: Assemble Doors	17
Part 4: Assemble Door Frame	19
Part 5: Assemble Internal Frame	20
Part 6: Drill Door Hinge Holes	26
Part 7: Assemble Battery Box	29
Part 8: Assemble Bottom Plate and Axles	33
Part 9: OPTIONAL. Paint Internal Frame and Handle	36
Part 10: Attach Bottom Plate	38
Part 11: Attach Dog Ears and Doors	39
Part 12: Assemble Side and Front Panels	42
Part 13: Attach Side and Front Panels	46
Part 14: Attach LED Box Face Plate	48
Part 15: Apply Decals	49
Finished Ghost Trap Images	50

DETAILS (Send Cut Sent Description):











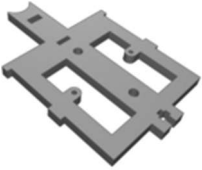

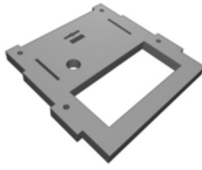
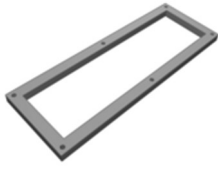

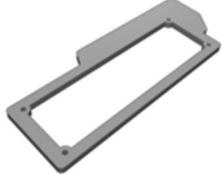
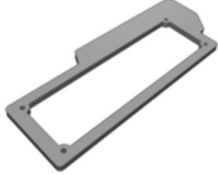

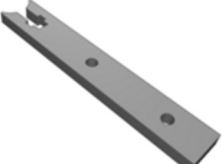

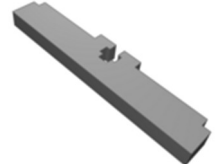
This listing provides a fully preconfigured aluminum Ghost Trap kit designed by Scavenger Workshop and ready to order directly through SendCutSend. Every part has already been set up with the correct aluminum type, thickness, and bend requirements.

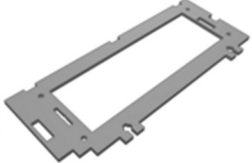
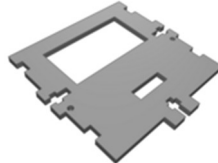
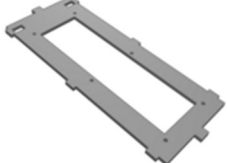



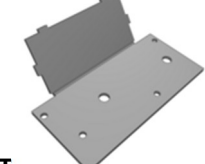

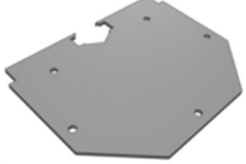

Instead of worrying about material selection, tolerances, or bend angles, everything is handled for you so you can confidently move straight to production. You simply review the parts, add them to your cart, and place your order. The kit includes all major aluminum components required to assemble the Ghostbusters Ghost Trap body, using 5052 H32 aluminum in multiple thicknesses with preconfigured bend operations where needed.

This version does not include the dog ears or axle components, as those require separate machining and must be sourced independently. This is a builder-focused project, not a finished product, and some basic finishing work should be expected such as light filing, cleanup, alignment, and optional body work like sanding, filler, and paint. This approach is intended to provide a streamlined, low-risk entry into aluminum prop building while still delivering a hands-on, authentic assembly experience.

Product Shown has been completed with additional parts not included. Side Tubes, Hat Lights, Knobs, Vector Plate, Resistor, Male Coupler and switches will need to be acquired from other suppliers a good resource for those supplies is <https://www.gbfans.com/shop/trap-parts/0/>

PARTS (Base Kit, Dog Ears, and Axles)

 <p>A</p>	 <p>B</p>	 <p>C</p>	 <p>D</p>
<p>5052 H32 Aluminum .250" 87.2 x 133.4 mm Qty: 1</p>	<p>5052 H32 Aluminum .250" 87.2 x 104.902 mm Qty: 1</p>	<p>5052 H32 Aluminum .250" 87.2 x 84.5 mm Qty: 1</p>	<p>5052 H32 Aluminum .250" 168 x 60 mm Qty: 1</p>
 <p>E</p>	 <p>F</p>	 <p>G</p>	 <p>H</p>
<p>5052 H32 Aluminum .250" 224 x 100 mm Qty: 1</p>	<p>5052 H32 Aluminum .250" 223.972 x 85.473 mm Qty: 1</p>	<p>5052 H32 Aluminum .250" 223.972 x 85.473 mm Qty: 1</p>	<p>5052 H32 Aluminum .063" 185.662 x 110.5 mm Qty: 1</p>
 <p>I</p>	 <p>J</p>	 <p>K</p>	 <p>L</p>
<p>5052 H32 Aluminum .125" 185.5 x 42.9 mm Qty: 1</p>	<p>5052 H32 Aluminum .250" 20 x 125.401 mm Qty: 1</p>	<p>5052 H32 Aluminum .250" 20 x 125.401 mm Qty: 1</p>	<p>5052 H32 Aluminum .250" 16.201 x 80.8 mm Qty: 1</p>
 <p>M</p>	 <p>N</p>	 <p>O</p>	 <p>P</p>
<p>5052 H32 Aluminum .125" 185.5 x 30.9 mm Qty: 1</p>	<p>5052 H32 Aluminum .125" 214 x 88.4 mm Qty: 2</p>	<p>5052 H32 Aluminum .125" 87.2 x 85.202 mm Qty: 1</p>	<p>5052 H32 Aluminum .125" 87.2 x 211.409 mm Qty: 1</p>
 <p>Q</p>	 <p>R</p>	 <p>S</p>	 <p>T</p>
<p>5052 H32 Aluminum .125" 185.5 x 36.9 mm Qty: 1</p>	<p>5052 H32 Aluminum .125" 185.5 x 36.9 mm Qty: 1</p>	<p>5052 H32 Aluminum .063" 60 x 68.83 mm Qty: 1</p>	<p>5052 H32 Aluminum .063" 80.4 x 67.55 mm Qty: 1</p>
 <p>U</p>	 <p>V</p>	 <p>W</p>	 <p>X</p>

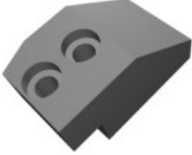
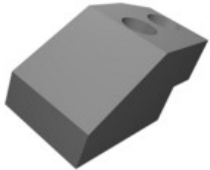
5052 H32 Aluminum .063" 87.2 x 62 mm Qty: 1	5052 H32 Aluminum .063" 87.2 x 70 mm Qty: 1	5052 H32 Aluminum .063" 192 x 66 mm Qty: 1	5052 H32 Aluminum .063" 192 x 66 mm Qty: 1
 Y	 Z	 AA	 BB
5052 H32 Aluminum .063" 47 x 63 mm Qty: 1	5052 H32 Aluminum .063" 38 x 64 mm Qty: 1	5052 H32 Aluminum .063" 87.2 x 68 mm Qty: 1	5052 H32 Aluminum .063" 58 x 30 mm Qty: 1
 CC	 DD	 EE	 FF
5052 H32 Aluminum .063" 30.5 x 54.925 mm Qty: 2	5052 H32 Aluminum .063" 30.5 x 60 mm Qty: 1	5052 H32 Aluminum .063" 8 x 21 mm Qty: 2	6061 T6 Aluminum 2.165" x 0.512" x 0.512" Qty: 2
 GG	 HH		
6061 T6 Aluminum 1.181" x 0.669" x 0.669" Qty: 1	6061 T6 Aluminum 1.181" x 0.669" x 0.669" Qty: 1		

HARDWARE

Image	Name	Material	Qty	D (mm)	L (mm)	Thread (mm)
	Hex Cap Head Screw	Passivated (Black)	5	M3	6	0.5
	Hex Cap Head Screw	Passivated (Black)	2	M3	10	0.5
	Hex Cap Head Screw	Passivated (Black)	8	M4	14	0.7
	Hex Socket Head Screw	Passivated (Black)	4	M3	4	0.5
	Hex Socket Head Screw	Passivated (Black)	12	M3	6	0.5
	Hex Socket Head Screw	Passivated (Black)	6	M3	8	0.5
	Hex Socket Head Screw	Passivated (Black)	2	M3	20	0.5
	Hex Socket Head Screw	Passivated (Black)	1	M6	35	1.0
	Hex Flat Head Screw	Passivated (Black)	5	M3	6	0.5
	Hex Flat Head Screw	Passivated (Black)	6	M4	10	0.7
	Hex Flat Head Screw	Passivated (Black)	2	M4	12	0.7
	Hex Flat Head Screw	Stainless Steel	5	M4	8	0.7
	Hex Flat Head Screw	Stainless Steel	4	M6	18	1.0
	Hex Flat Head Screw	Stainless Steel	2	M6	25	1.0
	Hex Nut	Stainless Steel	24	M3	N/A	0.5
	Hex Nut	Stainless Steel	19	M4	N/A	0.7
	Hex Nut	Stainless Steel	3	M6	N/A	1.0
	Dowel Pin	Stainless Steel	10	M3	6	N/A
	Dowel Pin	Stainless Steel	6	M3	8	N/A
	Dowel Pin	Stainless Steel	2	M3	10	N/A
	Tooth Star Lock Washer	Steel, 10mm ID	1	N/A	N/A	N/A

ADDITIONAL PARTS



Handle Tube

Part #: 4355

Dimensions: 3/4" OD x 0.065" Wall x 0.62" ID Aluminum Round Tube 6061-T6-Drawn
Custom Cut Length: 5"

Link: Onlinemetals.com



Tube Plugs

3/4 Inch (19mm) OD Round Plastic Hole Plugs

Link: Amazon

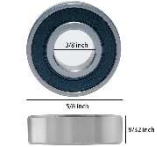

Wheels

R6-2RS Bearings 3/8 ID x 7/8 OD x 9/32 Width

Link: Amazon



Side Rods

1/2" diameter aluminum with a brushed anodized finish!

- The GB1 (Hero) style rods are 3-1/4 inches long.
- The GB2 (Stunt) style rods are 3 inches long. Sd

These rods feature two #6-32 mounting screws spaced 2-1/2 inches apart.

Link: GBFans



Front Cartridge Round Knobs

Mounts on a 1/8" OD shaft. Includes brass set screw.

Link: GBFans



Front Cartridge Rectangle Knobs

Unable to find exact part number.

Link: Free Test Models STL Download - ghostbusters trap Front Sqaure knobby DirtyDozen12

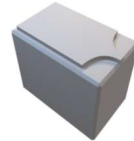

Foster Male Coupler (22-2B)

Accurate brass male coupler for main trap.

Link: GBFans



Red Light Lens and Socket

Linrose B4611B1

Red lens with mounting base and 12V incandescent bulb.

Link: GBFans



Side "Vector" Plate

GB1 plate: 3.5" x 1.75" wide,

GB2 plate: 3.5" x 2" wide

Link: GBFans



CAL-R MC250 Resistor

CAL-R Trap resistor that is mounted to the Vector Plate

Accurate gold in color with a heatsink on the top

Link: GBFans



Side Knob (GB1)

Black plastic

Attach to a 1/4" shaft with a flat, d-shaft, or keyed shaft

Link: [GBFans](#)

Link: [Etsy](#)



Side Knob (GB2)

Aluminum knurled knob with set screw

Attach to a 1/4" shaft

Link: [GBFans](#)

Link: [Etsy](#)



Tear Drop Knob (GB1)

Polycarbonate replica with machined aluminum center

Attach to 1/4" shaft with two #4-32 set screws

Link: [GBFans](#)

ZEDDEMORE INDUSTRIAL

CONSTRUCTION MATERIALS



J-B Weld Original Steel Reinforced Epoxy Syringe



Rust-Oleum 249322 Automotive Self Etching Primer



Rust-Oleum Canyon Black Satin Spray Paint



Rust-Oleum Automotive Gloss Acrylic Enamel Clear



Mineral spirits



E6000 Glue



Gorilla Micro Precise Super Glue Gel



Loctite Threadlocker Blue 242



Masking Tape

TOOLS

Required	Optional
Allen Wrenches (Metric)	Dremel
Crescent Wrench	Dremel Rotary Metal Files (optional)
Pliers	
Channel Locks	
Sandpaper (80 to 400+ Grit)	
Drill	
Drill Bits (3mm, 4mm, 6mm)	
Countersink Drill Bit	
Metal Files (flat, circular, large, and small)	
Clamps (2" to 12") – Several	

DECALS

Multiple options for decals, some popular ones are listed here.



MobySignCo
Material(s): Vinyl
Link: [Etsy](#)



LastTakeMedia
Material(s): Vinyl and Brushed Aluminum
Link: [Etsy](#)

ELECTRONICS

Feel free to mechanize as you see fit. Included here is a list of parts for a basic lights-only setup.

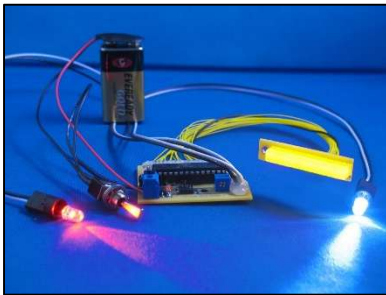

Light Kit
Jupiter Electronics
9V Kit
Link: [Etsy](#)



Rechargeable Battery Pack (Optional)
Jupiter Kit Compatible
9.6 V 3200 mAh NI-MH Battery Pack,
Rechargeable AA RC Car Battery, with USB
Charging Cable, KET 2P Connector
Link: [Amazon](#)
**Wire into the Jupiter kit if you desire a
rechargeable power option**

BUILD INSTRUCTIONS

Part 1: Assemble Segmented LED Box

Parts

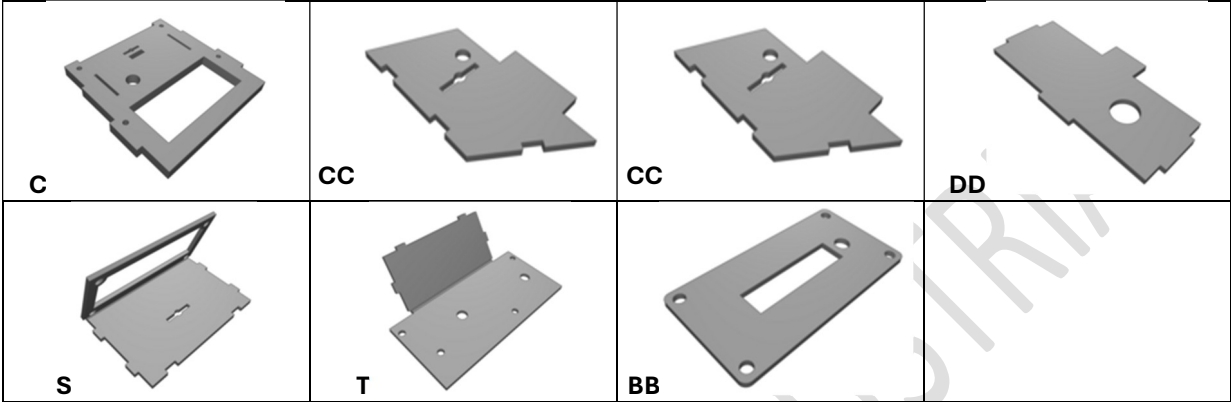

Hardware and Build Materials

- J-B Weld

Steps

1. Sand and file burrs on **Parts C, CC, DD, S, T, and BB.**

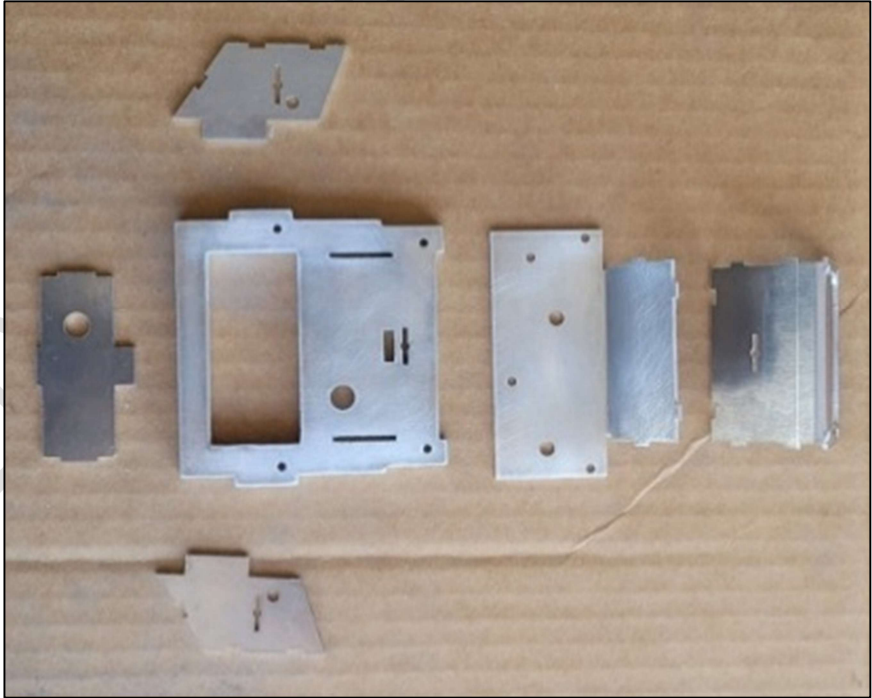

2. Dry fit all parts and file tabs, as necessary.

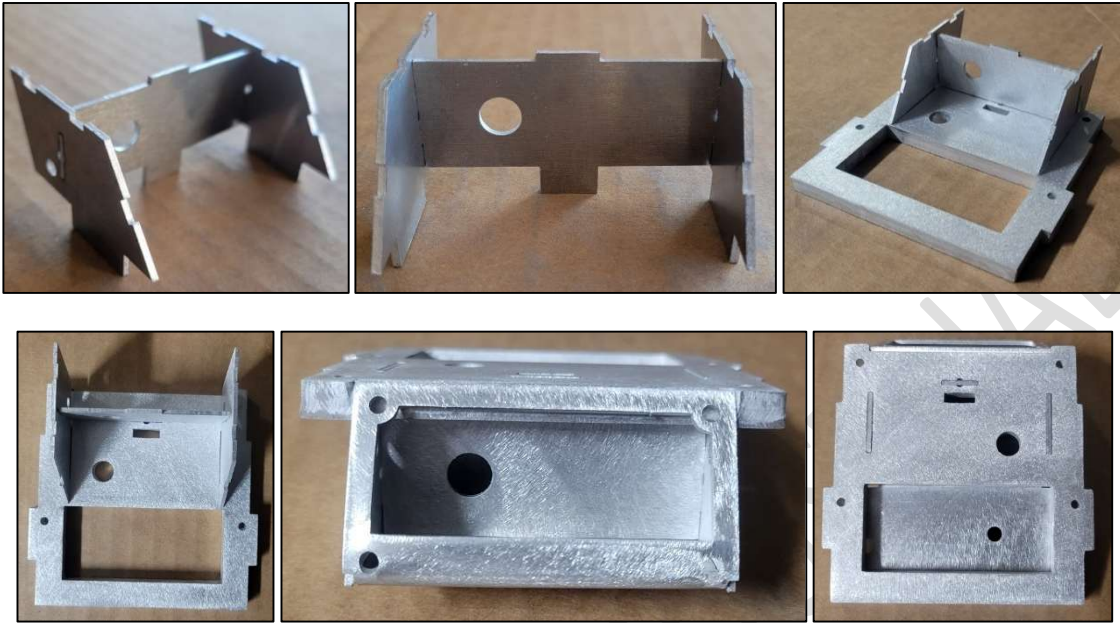

3. Separate parts, apply J-B Weld around all tabs and edges, and refit all parts. Apply more J-B Weld around edges, tabs, and holes to sand when cured (~24 hours). Clamp well.

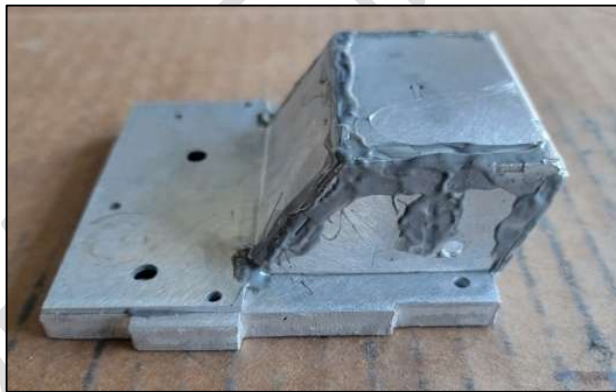

4. After J-B Weld has cured, thoroughly sand away all excess residue.

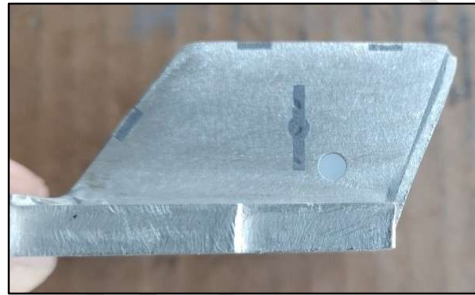
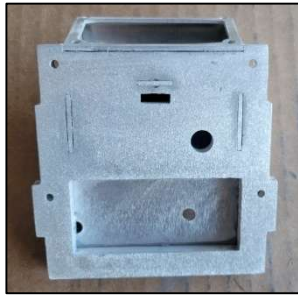
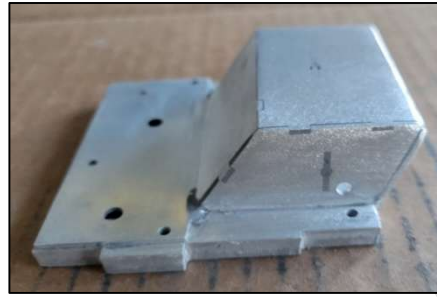
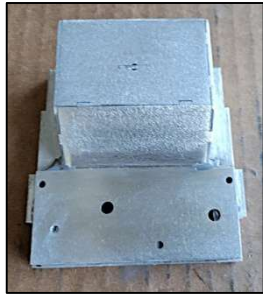

5. File the top opening of **Part S** to flatten any bulging metal caused by the production process. Ensure the face plate (**Part BB**) sits flush and the holes align.



Part 2: Assemble Handle Mount

Parts

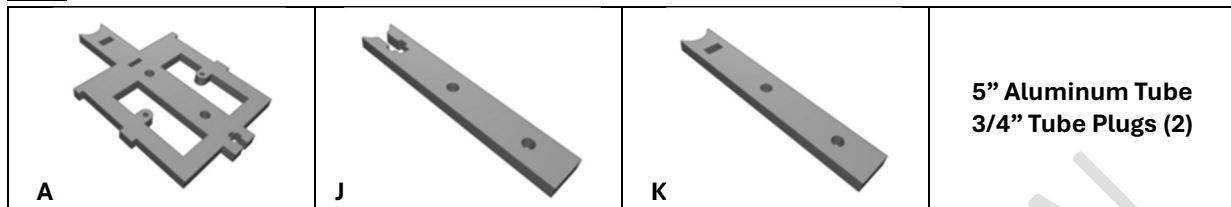

Hardware and Build Materials

- J-B Weld
- (2) M6x25mm Hex Flat Head Screws (Stainless Steel)
- (1) M6x35mm Hex Socket Head Screw (Passivated)
- (3) M6 Nuts (Stainless Steel)

Steps

1. Sand and file burrs on **Parts A, J, and K.**

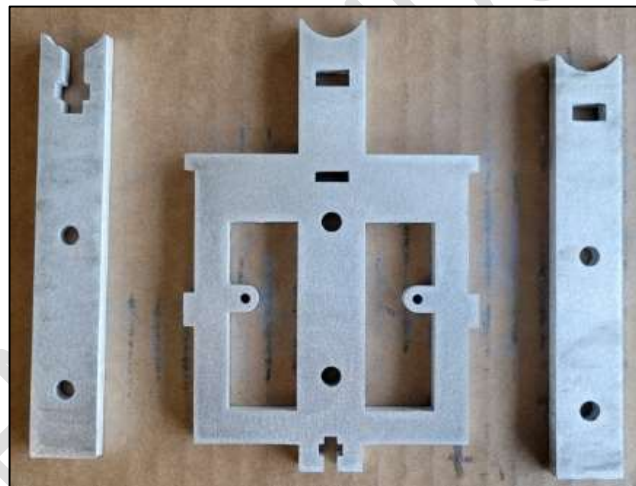

2. Insert an M6 nut in **Part J.**



3. Drill countersink holes in one side of **Part K.**



4. Dryfit parts with two M6x25mm Hex Flat Head Stainless Steel Screws and M6 Nuts (Stainless Steel), sand and file as necessary.

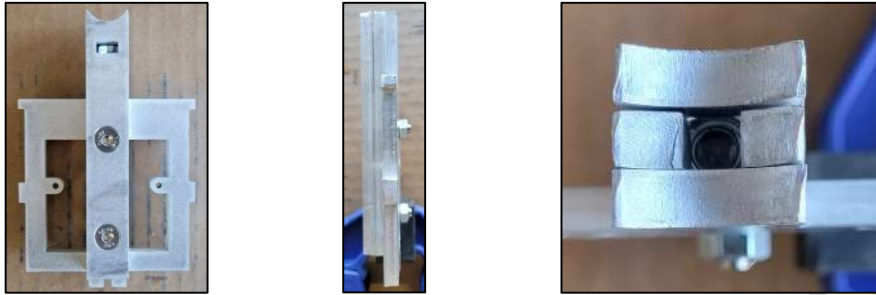

5. Separate parts, apply J-B Weld between each, and reattach with screws and nuts. Bolt firmly. Do not get glue in the nut threads in Part J. Cover the seams of the square shaft with J-B Weld to sand when cured. Clamp well to firmly bond all parts, especially near the top concave portion of the square shaft.

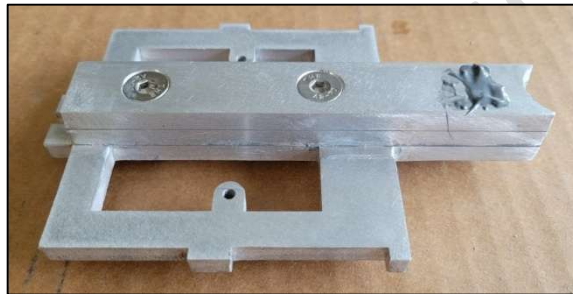

6. Sand all parts smooth once J-B Weld has fully cured (~24 hours).



7. Install two 3/4" Tube Plugs into the 5" aluminum tube. Mark the 5" metal tube ~10-12mm from one end and drill a 6mm hole directly through the center.



8. Mount the tube to the handle mount with an M6x35mm Hex Socket Head Screw.



Part 3: Assemble Doors

Parts

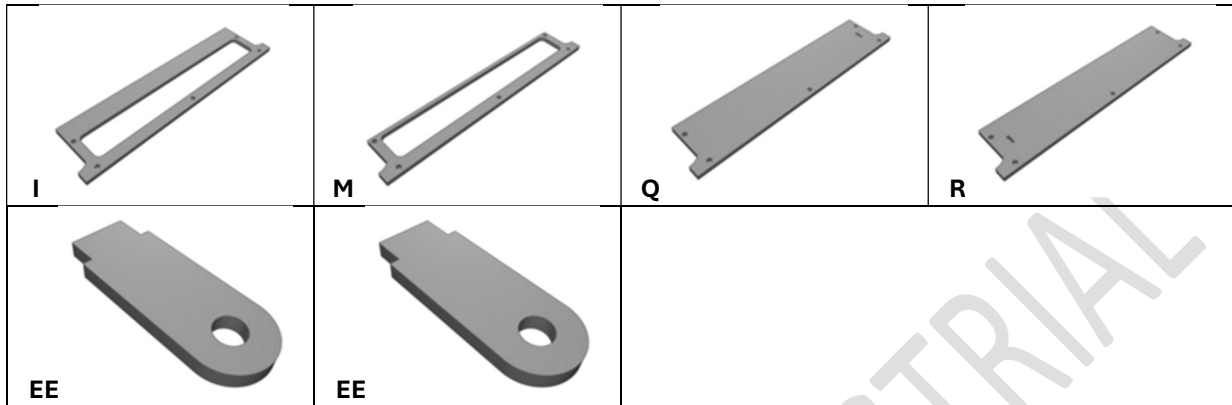

Hardware and Build Materials

- J-B Weld
- (10) M3x6mm Dowel Pins (Stainless Steel)

Steps

1. Sand and file burrs on **Parts I, M, Q, and R.**

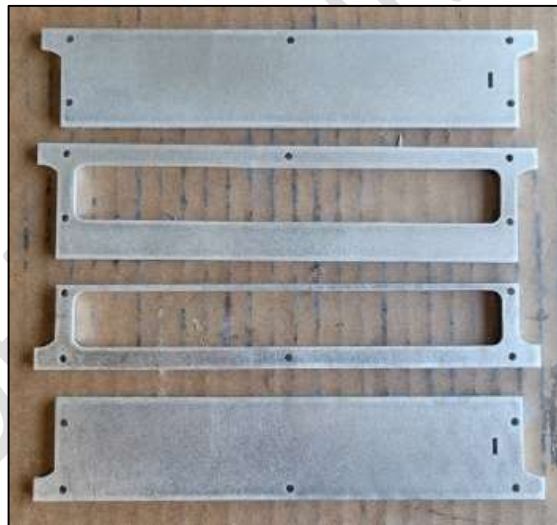

2. Dry fit parts and ensure door notches are on the same side.



3. Apply J-B Weld between the door components and drive M3x6mm Dowel Pins into each hole to maintain alignment. Apply J-B Weld to small tabs (part EE) and insert them into slots. Wipe away all excess glue. Clamp well until J-B Weld has fully cured (~24 hours).

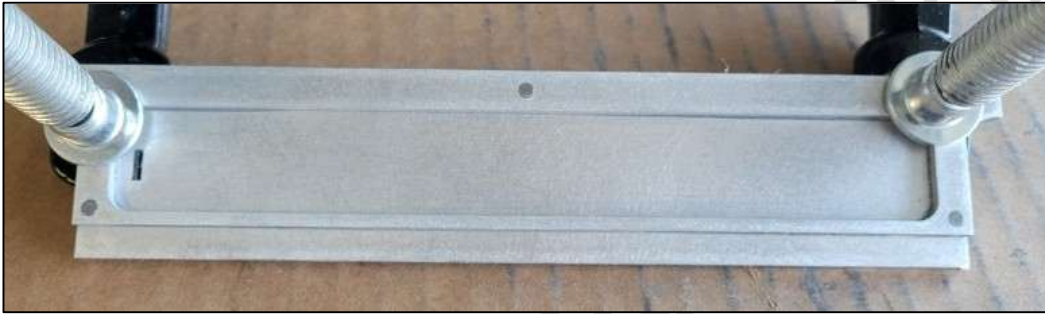

4. Remove any dried J-B Weld.
OPTIONAL. Slightly file the outside tab edges for better Door Frame clearance.



Part 4: Assemble Door Frame

Parts

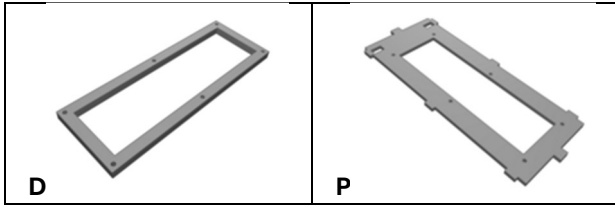

Hardware and Build Materials

- J-B Weld
- (6) M3x8mm Dowel Pins (Stainless Steel)

Steps

1. Sand and file burrs on **Parts D and P.**

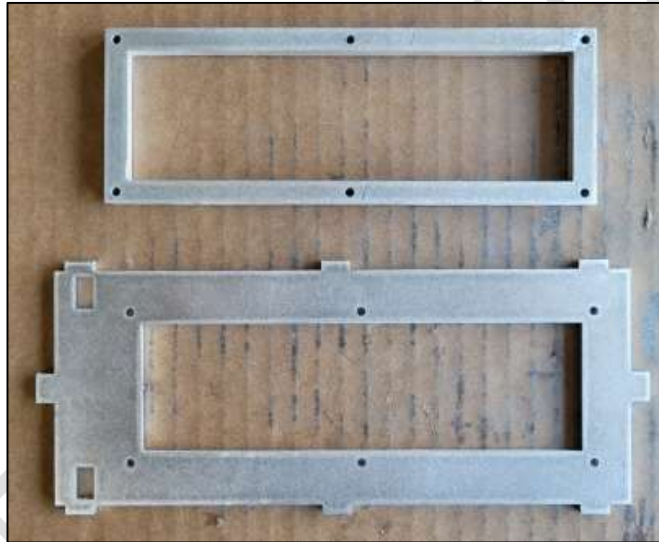



2. Apply J-B Weld between the components and hammer M3x8mm Dowel Pins into each hole to maintain alignment. Wipe away excess glue. Clamp until J-B Weld is fully cured (~24 hours).

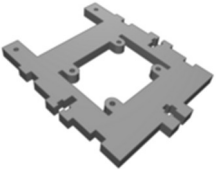
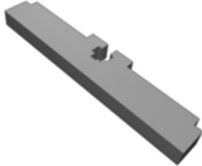
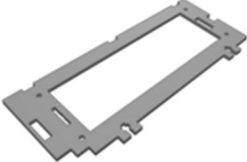
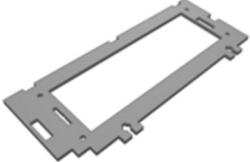

Part 5: Assemble Internal Frame

Parts

 B	 L	 N	 N
 O	Segmented LED Box (from Part 1)	Handle Mount (from Part 2)	Door Frame (from Part 4)

Hardware and Build Materials

- J-B Weld
- (5) M4x8mm Hex Flat Head Screws (Stainless Steel)*
*Only (4) M4x8mm Hex Flat Head Screw (Stainless Steel) will be required in future designs
- (19) M4 Nuts (Stainless Steel)*
*Only (10) M4 Nuts will be required in future designs

Steps

1. Sand and file burrs on **Parts B, L, N, and O.**



2. Assemble the **Inner Bracket (Parts L and O)**. Insert an M4 nut in **Part L**. Insert **Part L** into **Part O** and drill a countersink hole. Attach with an M4x8mm Hex Flat Head Screw.

Note: this will be assembled with J-B Weld instead of a nut and screw in future design versions.

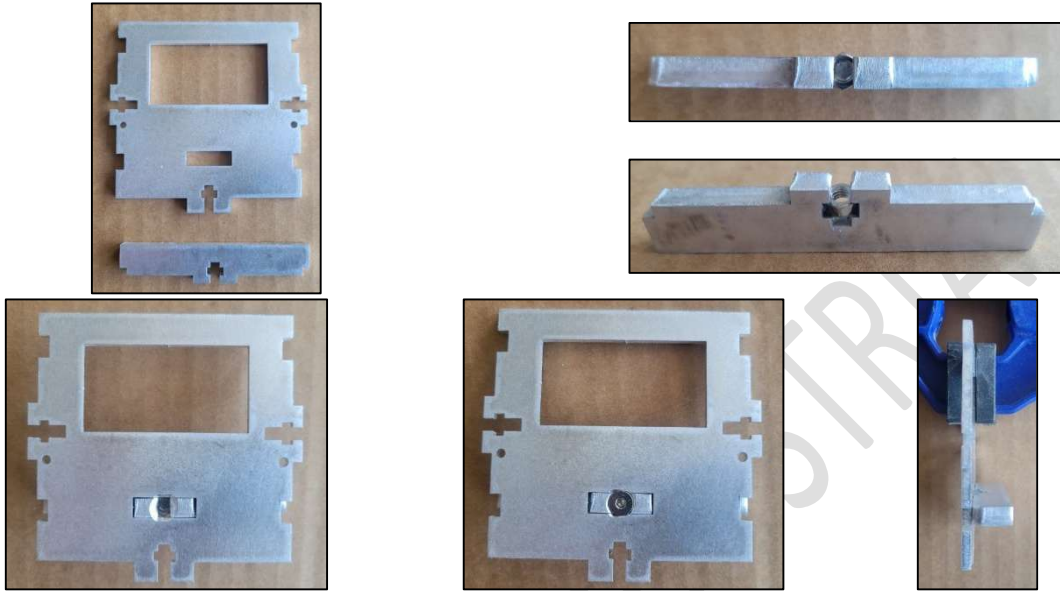

3. Dry fit all parts of the inner frame and file tabs until they easily slide into place. The prescribed assembly steps are shown in the below sequence.

3.a. Insert **Part B** into the **Door Frame** slots.



3.b. Insert the **Handle Mount** at the same end of the **Door Frame**.



3.c. Insert the **Segmented LED Box** on the other end of the **Door Frame**. Set aside.



3.d. Lay one **Part N** flat on the table.

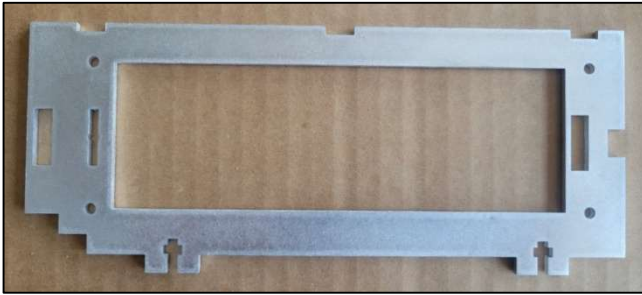

3.e. Insert the **Inner Bracket** (from step 2) into **Part N**.

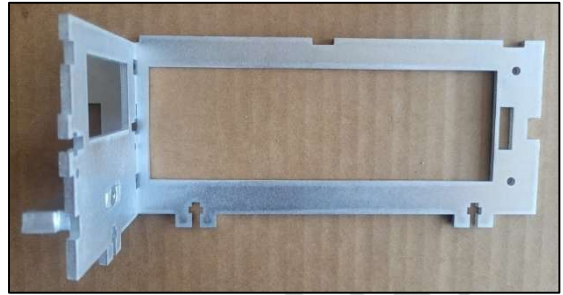

3.f. You should have two sub assemblies that look like this.

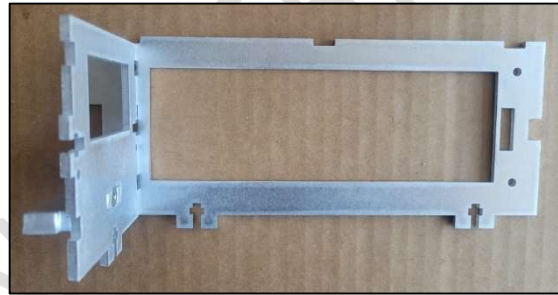
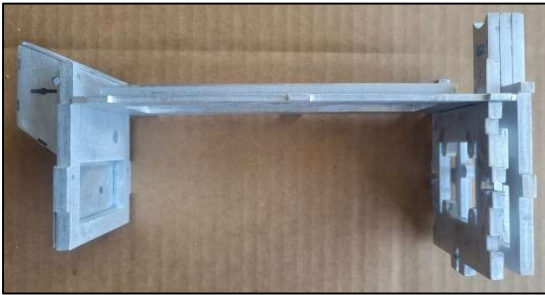

3.g. Place the left sub assembly onto the right sub assembly and push the tabs of the **Segmented LED Box**, **Handle Mount**, and **Part O** into the slots on **Part N**. Then attach the second **Part N**.



3.h. Ensure everything is flush and firm. Sand and file as necessary.

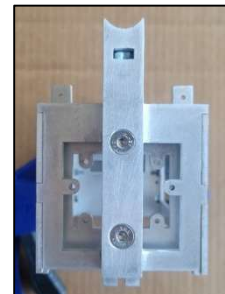
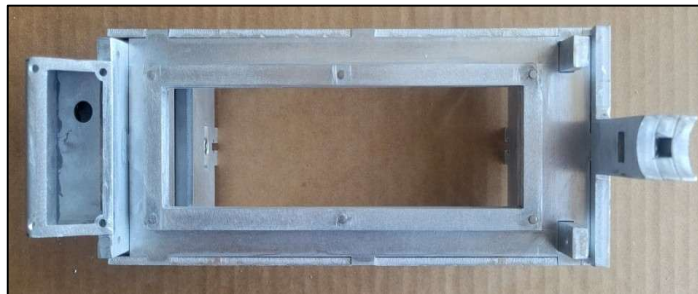

4. After everything fits properly, take everything apart and insert ten M4 Nuts (Stainless Steel) into all remaining nut holder tabs on **Parts B, O, and N**. Affix with super glue.

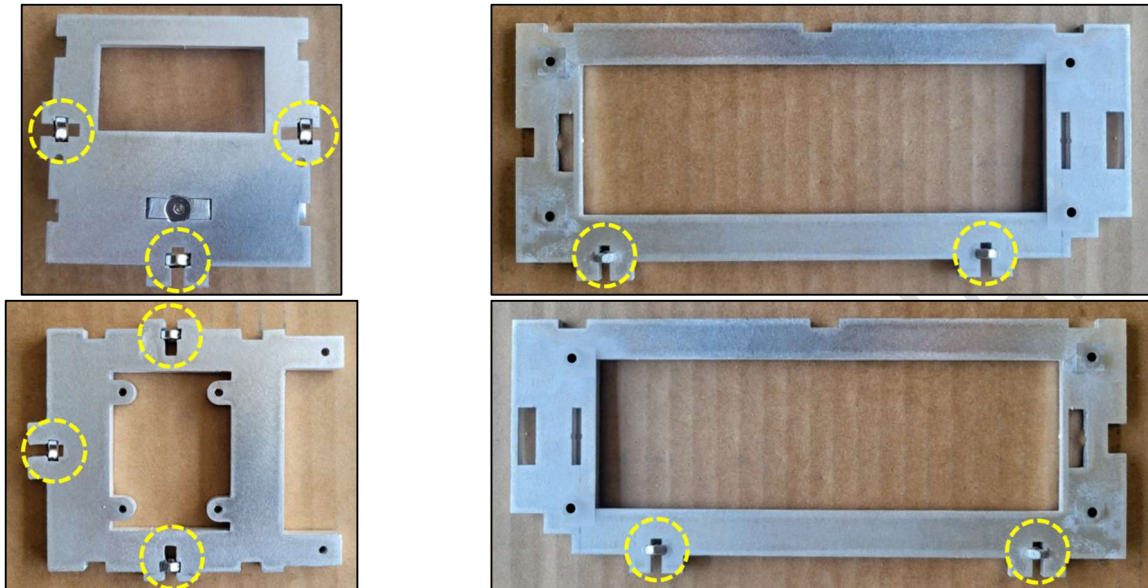

5. Adhere eight M4 Nuts (Stainless Steel) behind the holes on the internal-facing walls of both **Parts N**. This enables you to bolt on the larger side panels (**Parts F and G**) so they can be removed to access the trap internally.

To do this, reassemble the internal frame and align M4 Nuts (Stainless Steel) to fit in the notches (images on the right). Use M4 bolts to temporarily hold the nuts in place and adhere with super glue.

Note: these holes will be pre-tapped in future design versions.

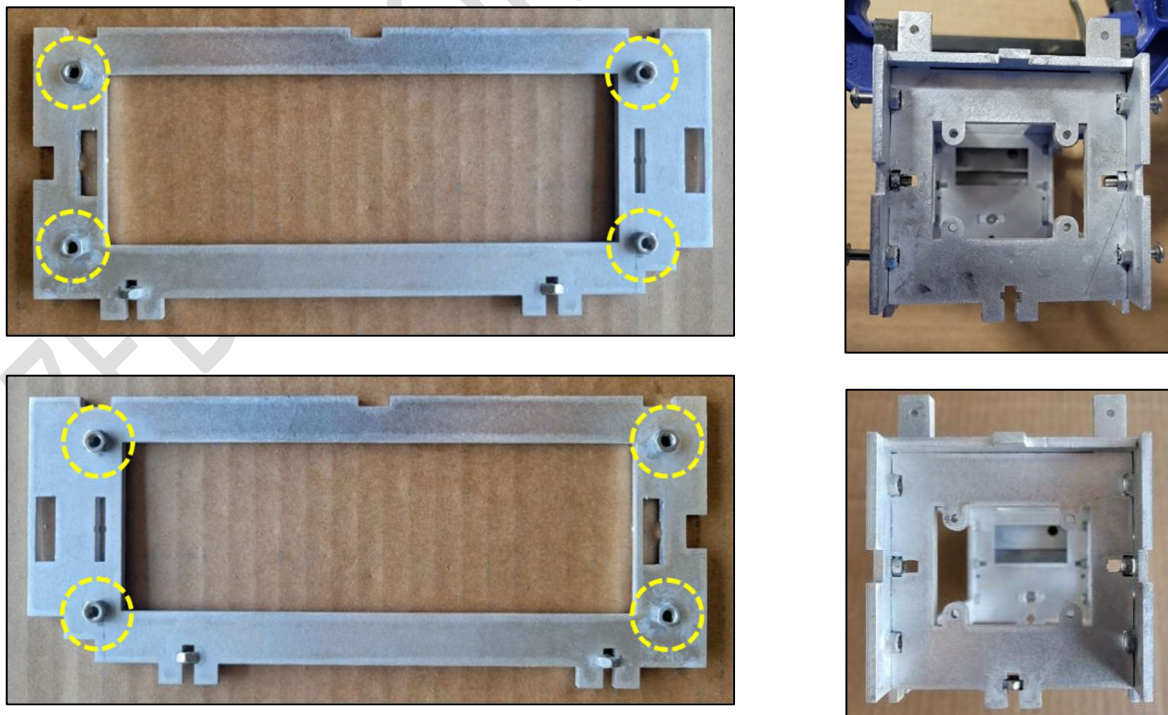

6. **OPTIONAL.** Notch two channels in Part B with a dremel or other cutting tool. This will ensure the wheels have proper clearance. **Note:** these notches will be pre-cut in future design versions.

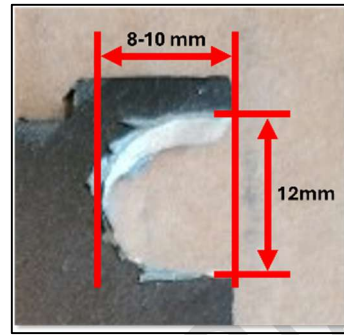
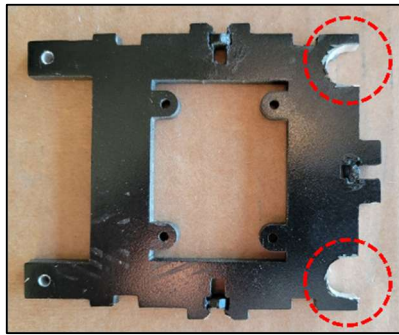

7. **OPTIONAL.** Paint the interior sections of the internal frame (**Parts B, L, N, and O**) if you desire them to be black before further construction.



8. Once all nuts are affixed and the internal frame is reassembled (from Step 5), drill four countersink holes in the junction tabs of **Parts B, O, and N** (two on each side of the trap). Attach with four M4x8mm Hex Flat Head Screws. Ensure the screw heads are flush or slightly inset.



9. Disassemble the internal frame again and apply J-B Weld to the top seams and tabs, and the rectangular notches on **Part N**. Reassemble, insert screws, and wipe away all excess glue from internal joints. Clamp well and let cure (~24 hours).



10. When cured, sand away all excess J-B Weld until the seams are smooth.

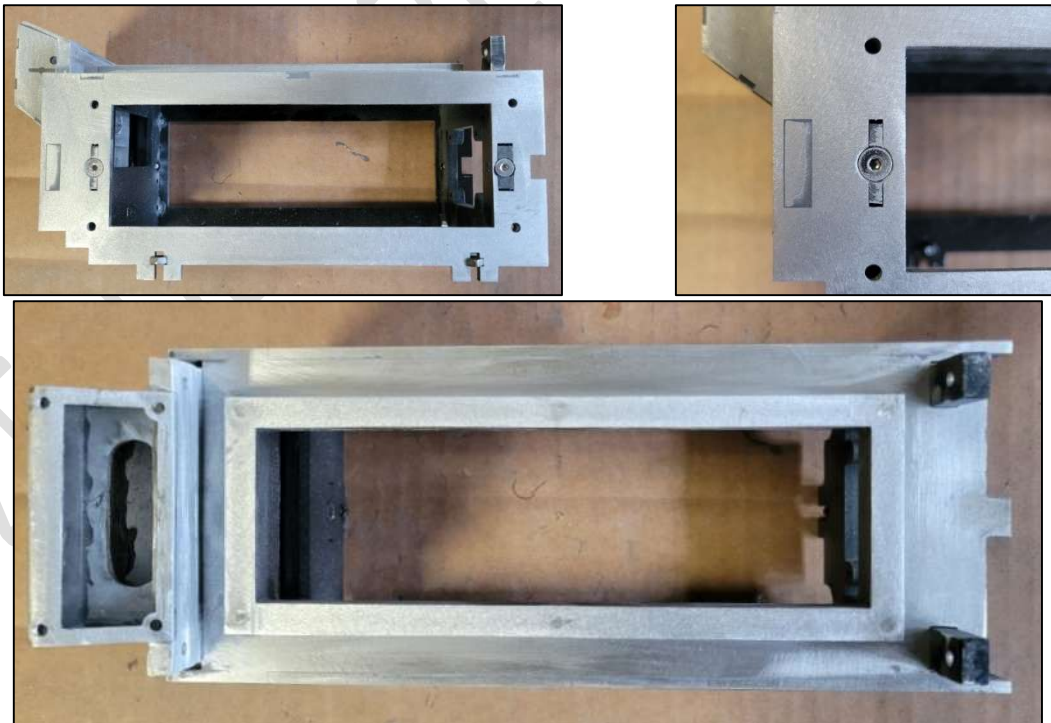

Part 6: Drill Door Hinge Holes

Parts

Doors (from Part 3)	Internal Frame Assembly (from Part 5)
--------------------------------	--

Hardware and Build Materials

- None

Steps

1. Place a 1-1.5mm spacer on the top of the internal frame. The battery box top and bottom plates (**Parts U and V**) work well. This is to ensure the doors clear the door frame when opened.

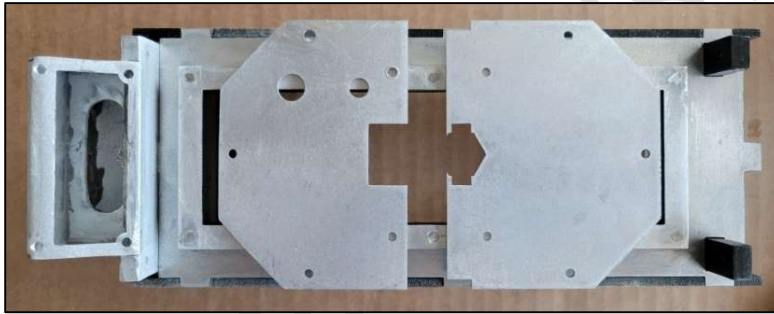

2. Align the doors on the top of the spacers. Center the door ends on the posts at all four corners and ensure the door edges are flush and everything lays flat.



3. Verify a uniform gap between the doors and the door frame.

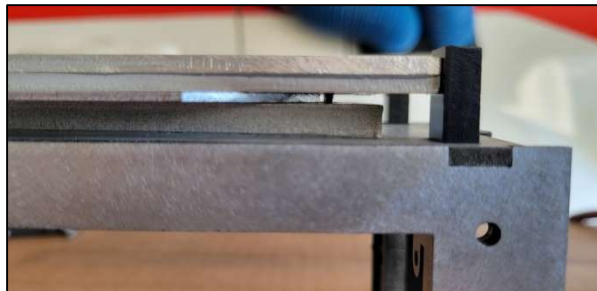

4. Tape the doors together with masking tape to keep them flush and clamp them tightly to the internal frame.

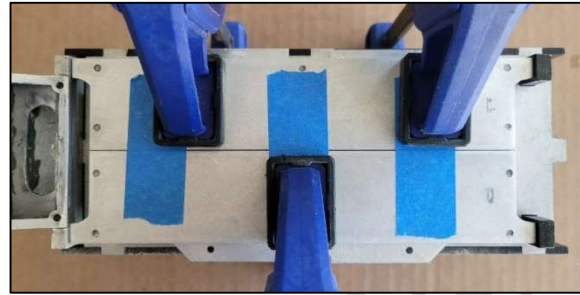
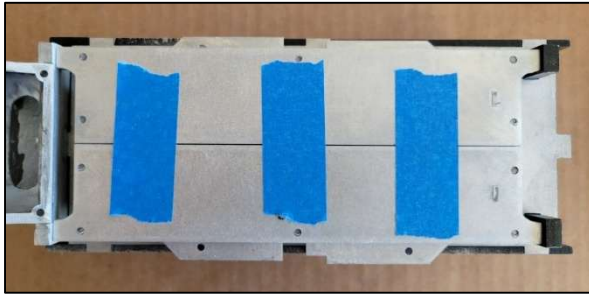

5. Place a mark on the door 10mm from the outer edge of a post, and mark a 3mm drill bit accordingly (making tape works well). Slowly drill into the side of door using the 3mm hole in each post as a guide.

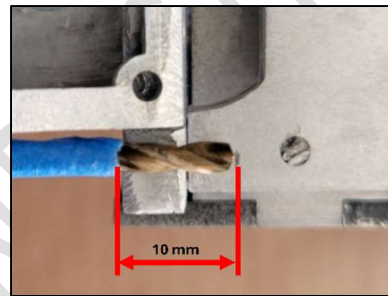
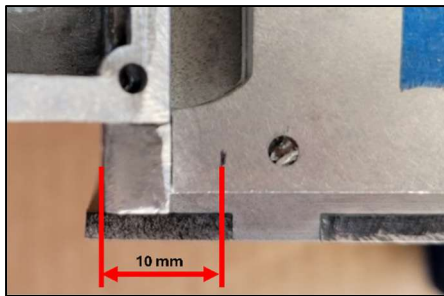

6. Place M3x10mm screws through each post into the doors as a guide to ensure you drilled far enough and everything feels flush and secure.

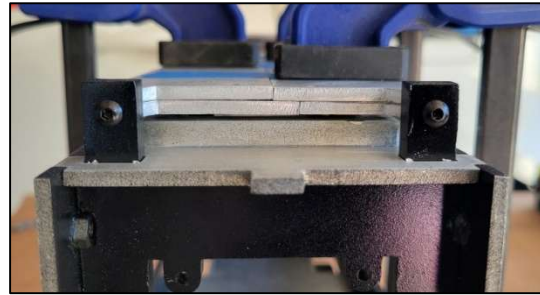

7. Remove the plates and verify the doors open smoothly. The doors will very slightly droop in the center. This is OK and they can be leveled with servos and mounts if you choose to mechanize the trap.

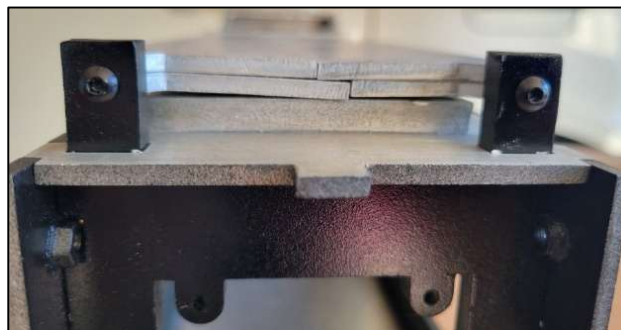

8. If the doors slightly catch on the door frame inner edge, remove the doors and file the edges of the frame until they easily clear.

Doors fully open.



File these edges, if necessary.

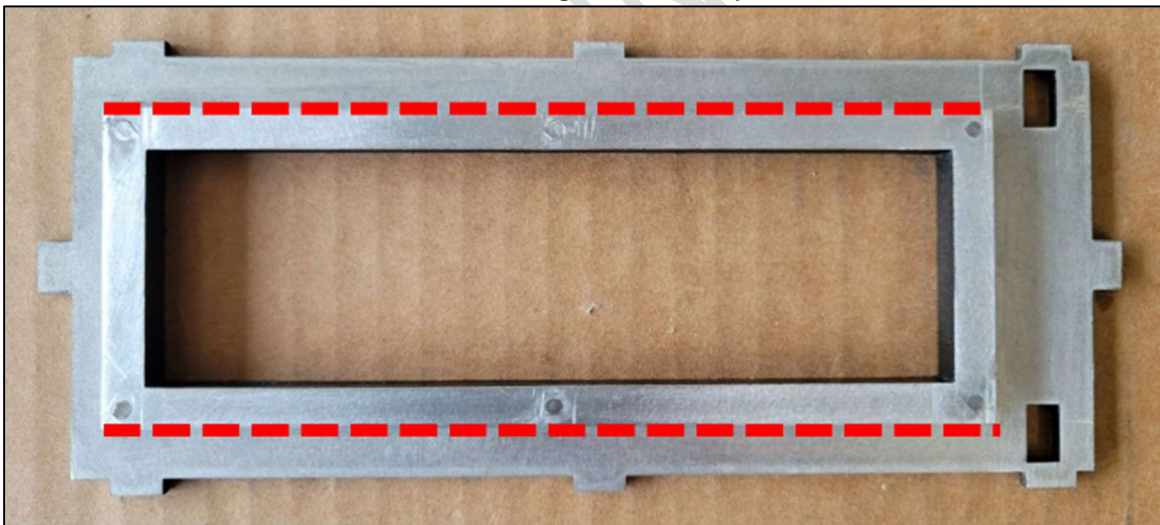

Part 7: Assemble Battery Box

Parts

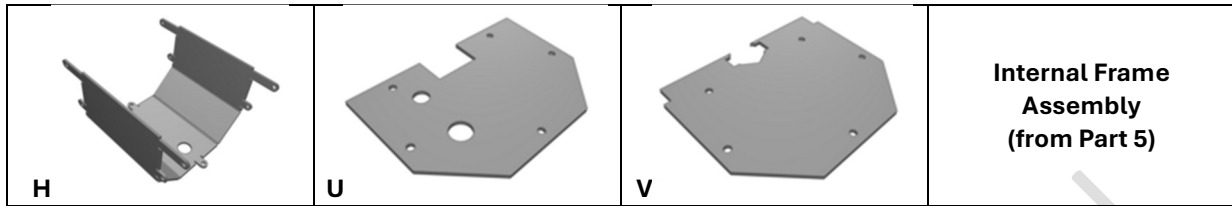

Hardware and Build Materials

- J-B Weld
- Thread Locker (optional)
- (5) M3x6mm Hex Flat Head Screws (Passivated)
- (5) M3x6mm Hex Cap Head Screws (Passivated)
- (10) M3 Nuts (Stainless Steel) or (10) M3 Lock Nuts
- (1) Tooth Star Lock Washer (10mm ID) (Steel)

Steps

1. Sand and file burrs on **Parts H, U, and V.**

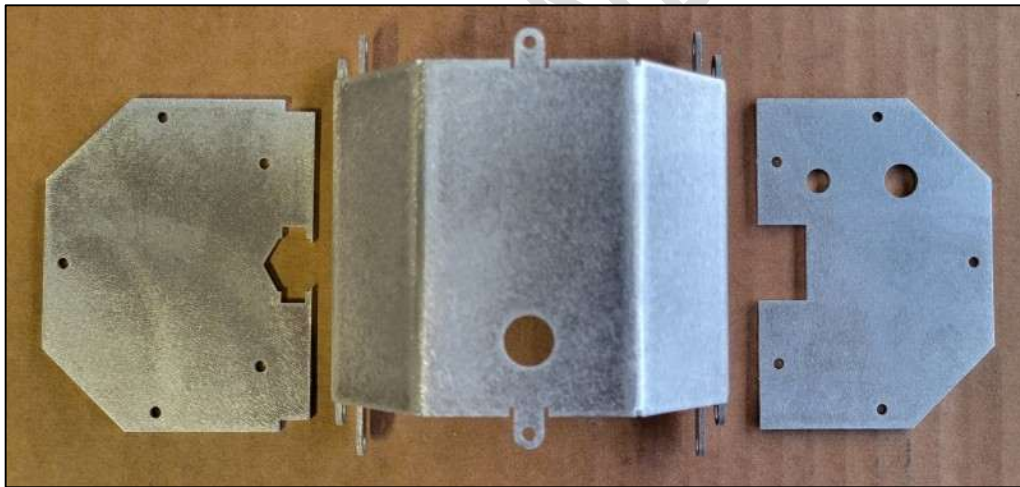

2. Inspect **Part H** for proper manufacturing bends. The bends should align with the small notches at the top and bottom. If they do not, contact the vendor for a replacement.

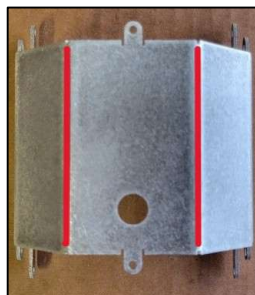
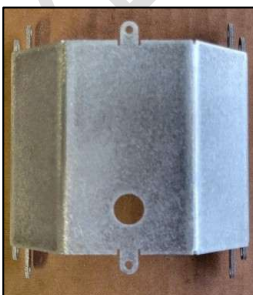

3. Bend the tabs on **Part H**. Use a pair of pliers or channel locks and grip at the very bottom of each tab. Once bent, ensure they are flush with the top and bottom edges of the box to avoid gaps between the box and the plates. If not, carefully unbend and re-bend as necessary.

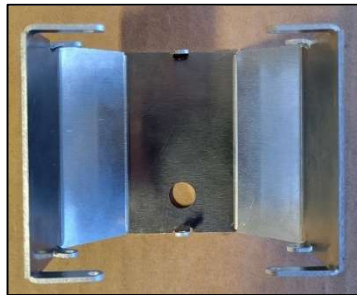
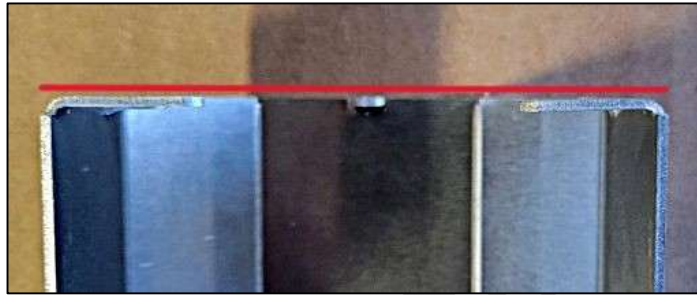

4. Drill countersink holes in the bottom plate (**Part V**) and affix to the box with M3x6mm Hex Flat Head Screws (Passivated) and M3 Nuts (Stainless Steel). Ensure the screw heads are flush. Consider using thread lock or lock nuts to avoid the nuts loosening.

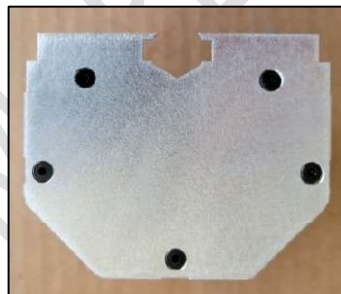
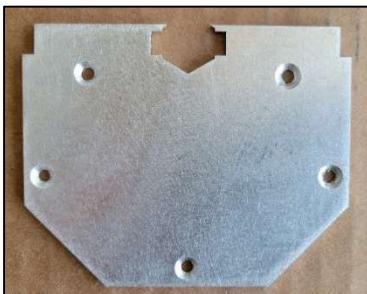

5. Attach the top plate (**Part U**) with M3x6mm Hex Cap Head Screws and M3 Nuts (Stainless Steel) to ensure a tight fit.

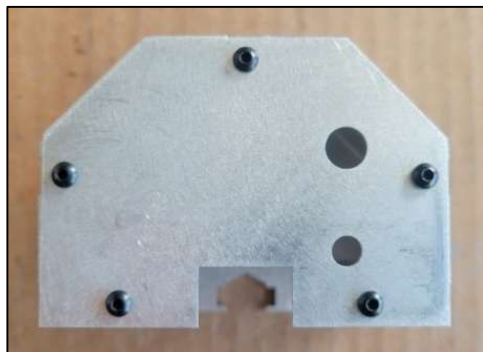

6. Dry fit the battery box to the internal frame and verify everything aligns properly.

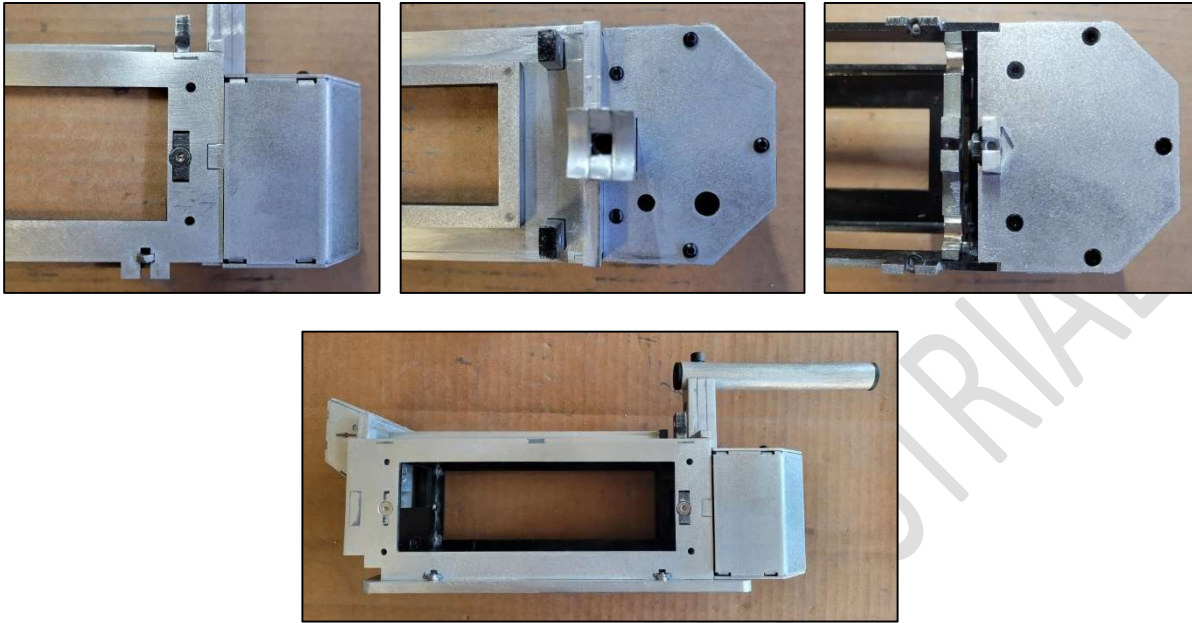

7. Attach the handle mount assembly from **Part 2** to the rear of the internal frame using J-B Weld. Attach the bottom plate (**Part E**) while the glue is wet to ensure the tabs and holes align. Clamp well. Sand the edges smooth once the J-B Weld has cured (~24 hours).



8. **OPTIONAL.** The battery box may protrude from the sides by ~1mm. Once the side panels (**Parts F and G**) are firmly affixed, the sides of the battery box may push inward. However, if this does not work, then consider elongating the side holes on the top and bottom tabs of battery box towards the bend.

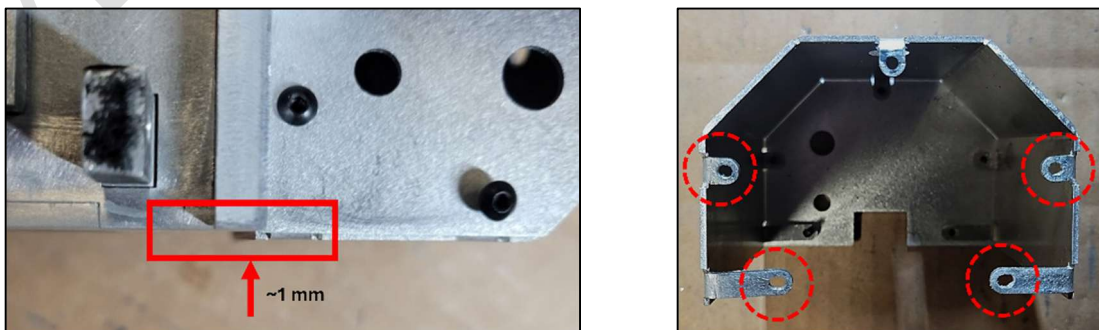

9. **OPTIONAL**. Paint the battery box.



10. Install the **Linrose B4611B1 Red Light Lens** and any electronics and switches in the top plate (**Part U**). Affix the the **Foster Male Coupler (22-2B)** with a steel Tooth Star Lock Washer (10mm ID) – the teeth may need to be bent a bit to fit properly (you can also just use glue). Reattach the top and bottom plates with five M3x6mm Hex Flat Head Screws (bottom), five M3x6mm Hex Cap Head Screws (top), and ten M3 Nuts. Consider using thread locker or lock nuts.

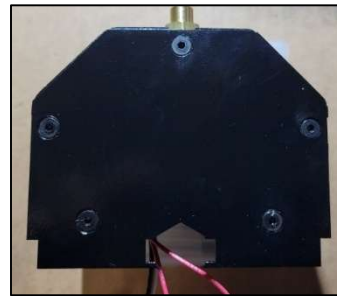
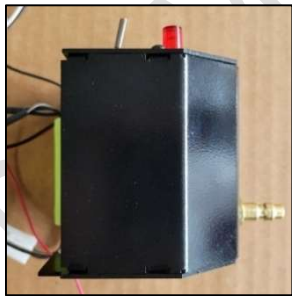
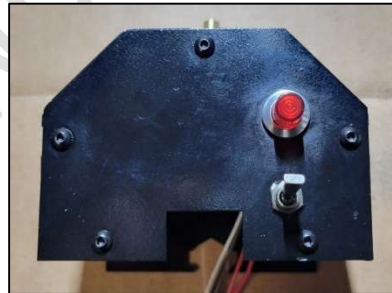
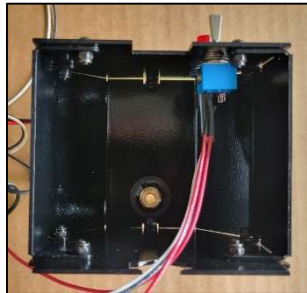

Part 8: Assemble Bottom Plate and Axles

Parts



Hardware and Build Materials

- Thread Locker (optional)
- (4) M6x18mm Hex Flat Head Screws (Stainless Steel)
- (2) M4x12mm Hex Flat Head Screws (Passivated)

Steps

1. Sand and file burrs on **Parts E and FF**.

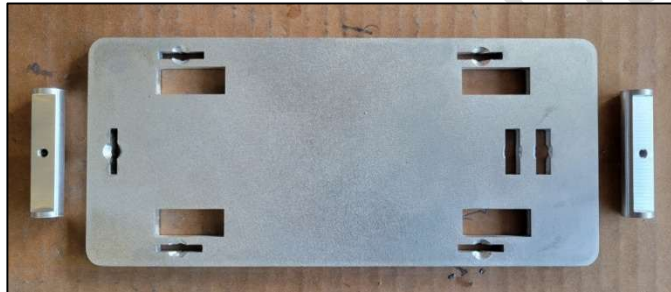

2. Measure and drill 4mm holes to attach the axles and countersink them.

Note: these holes will be pre-drilled in future design versions.

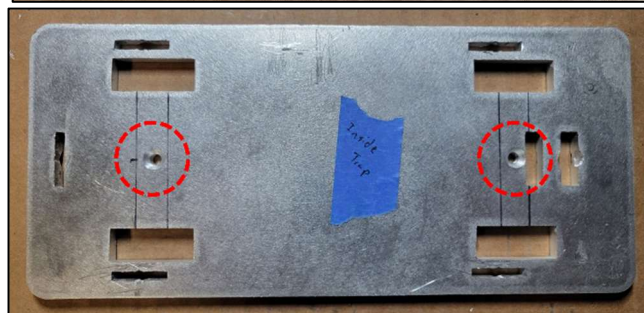

3. **OPTIONAL**. Clean up the bottom plate and paint it.

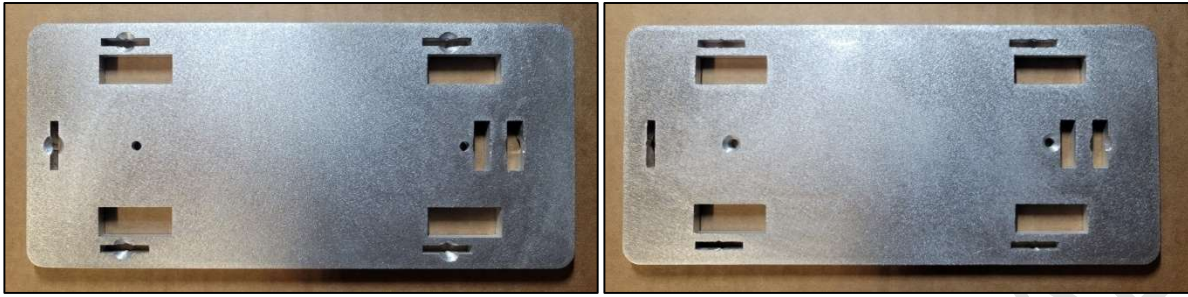

4. Attach the **Wheels** (R6-2RS Bearings 3/8 ID x 7/8 OD x 9/32 Width) to the axles using four M6x18mm Hex Flat Head Screws. Consider using thread lock to ensure the screws remain in place.
OPTIONAL. Paint the axles before attaching the wheels.



5. Attach the axles and wheels to the bottom plate (**Part E**) with two M4x12mm Hex Flat Head Screws (Passivated). Ensure the screw at the trap's rear is flush or slightly recessed and the screw head doesn't overhang the rectangular notch. If it does, file the screw head.

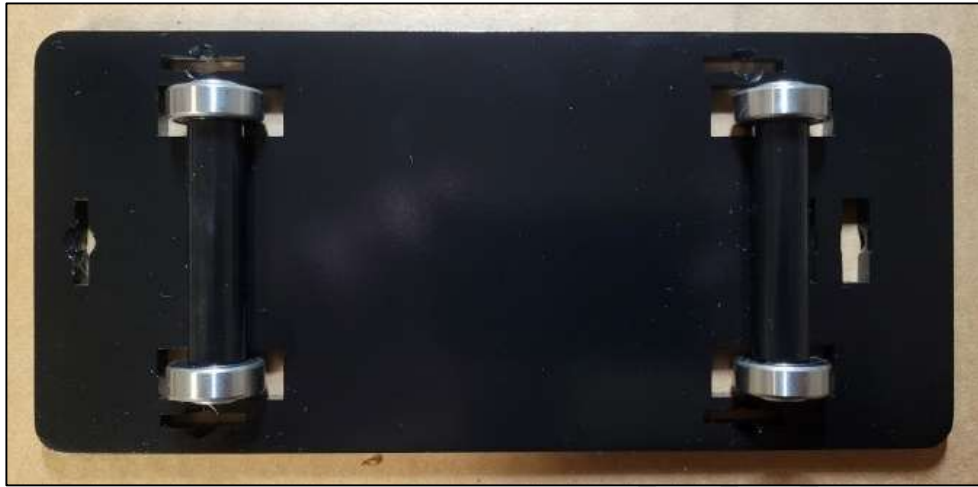

Part 9: **OPTIONAL**. Paint Internal Frame and Handle

Parts

**Internal Frame
Assembly
(from Part 5)**

Hardware and Build Materials

- Primer, Paint, and Sealant

Steps

1. Sand and thoroughly clean the internal frame and handle with mineral spirits.



2. Place cardboard inside the trap to mask the painted internal painted sections.



3. Apply several coats of self-etching primer and let cure (~30-60 minutes) between each coat.



4. Apply 2-3 coats of black paint and let cure (24-48 hours). Then, apply 2-3 coats of clear gloss enamel and let cure (24-48 hours).



Part 10: Attach Bottom Plate

Parts

Internal Frame Assembly (Part 5 / 9)	Bottom Plate and Axles (Part 8)
---	--

Hardware and Build Materials

- (6) M4x10mm Hex Flat Head Screws (Passivated)

Steps

1. Fit the bottom of plate with wheels attached to the frame. Ensure everything fits flush and fasten with six M4x10mm Hex Flat Head Screws (Passivated).

Note: the screw hole under the rear axle is blocked but it is not necessary for stability. Future design version will omit this screw.

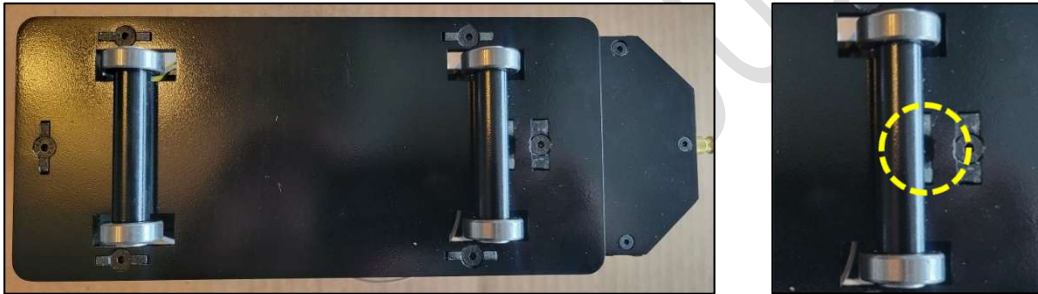

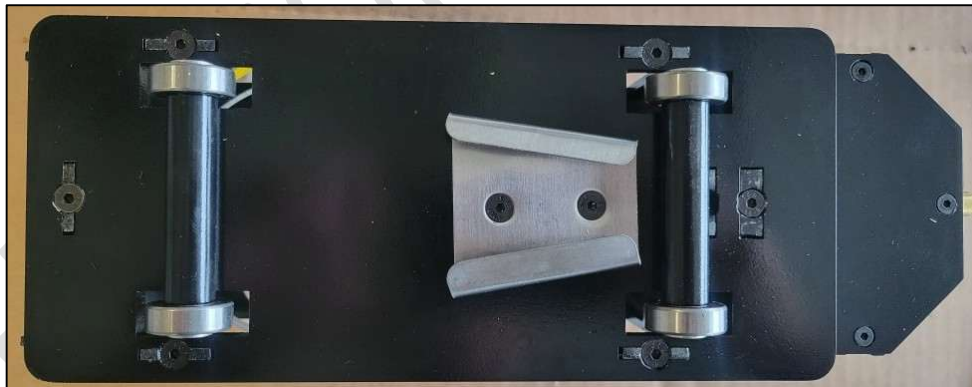

2. **OPTIONAL.** Attach a V-Hook to the plate, if desired.

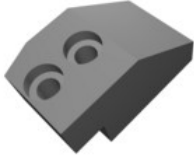

Part 11: Attach Dog Ears and Doors

Parts

 GG	 HH	Doors (Part 3)	Internal Frame Assembly (Part 5 / 9)
--	--	---------------------------	---

Hardware and Build Materials

- (2) M3x4mm Hex Socket Head Screws (Passivated)
- (2) M3x20mm Hex Socket Head Screws (Passivated)
- (2) M3x10mm Hex Cap Head Screws (Passivated)
- (2) M3x10mm Dowel Pins (Stainless Steel)
- (2) M3 Nuts (Stainless Steel)

Steps

1. Sand and file burrs on **Parts GG and HH**. Install an M3x20MM Hex Socket Head Screw (Passivated) and an M3x20mm Hex Socket Head Screw (Passivated) in the inserts of each dog ear.

OPTIONAL. Paint **Parts GG and HH**.



2. **OPTIONAL.** Apply yellow and black warning decals to the doors, or paint them.



3. Align the doors to the posts as done in **Part 3**.

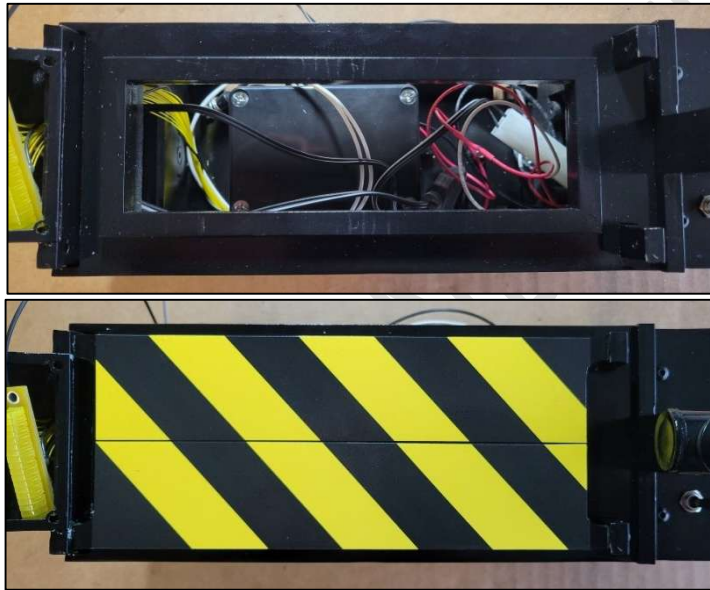

4. Insert two M3x10mm Dowel Pins (Stainless Steel) in the front posts/doors and two M3x10mm Hex Cap Head Screws (Passivated) in the rear posts/doors.

Front Posts (Pins)

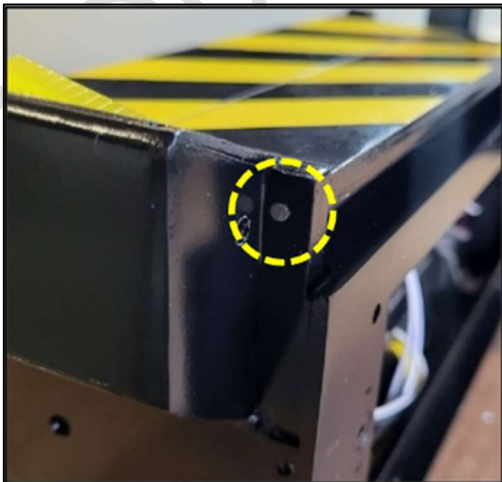

Rear Posts (Screws)

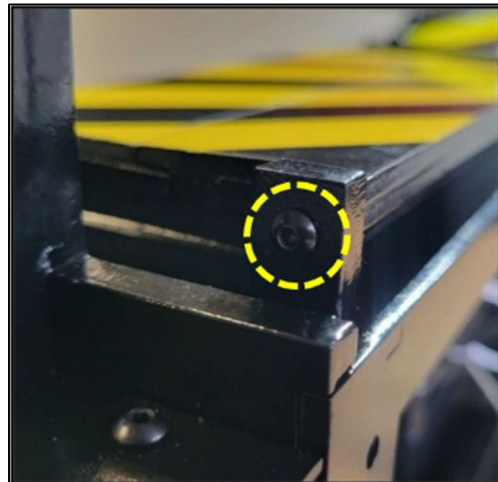

5. Ensure the doors open smoothly



6. Attach the dog ears (**Parts GG and HH**) on the front of the trap with M3 Nuts (Stainless Steel).

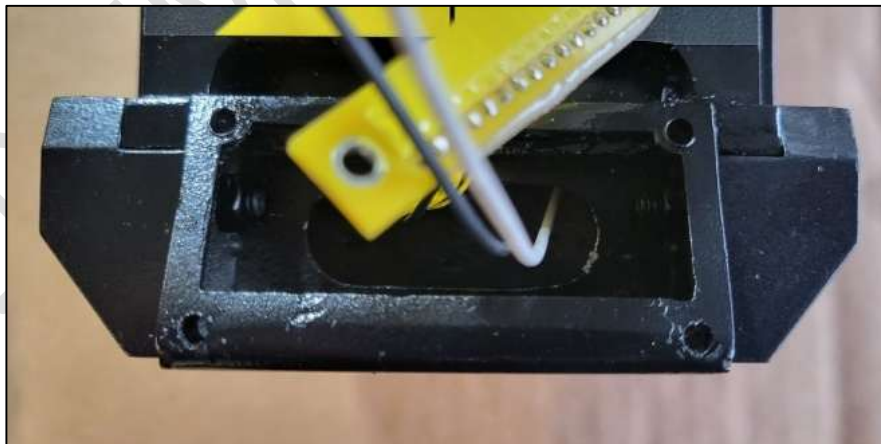
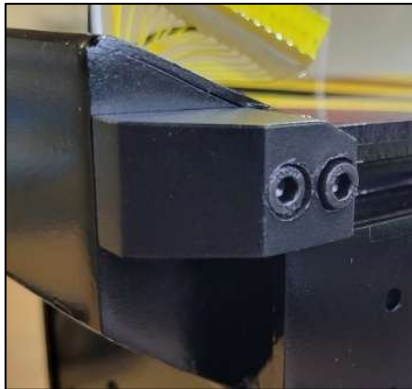

Part 12: Assemble Side and Front Panels

Parts

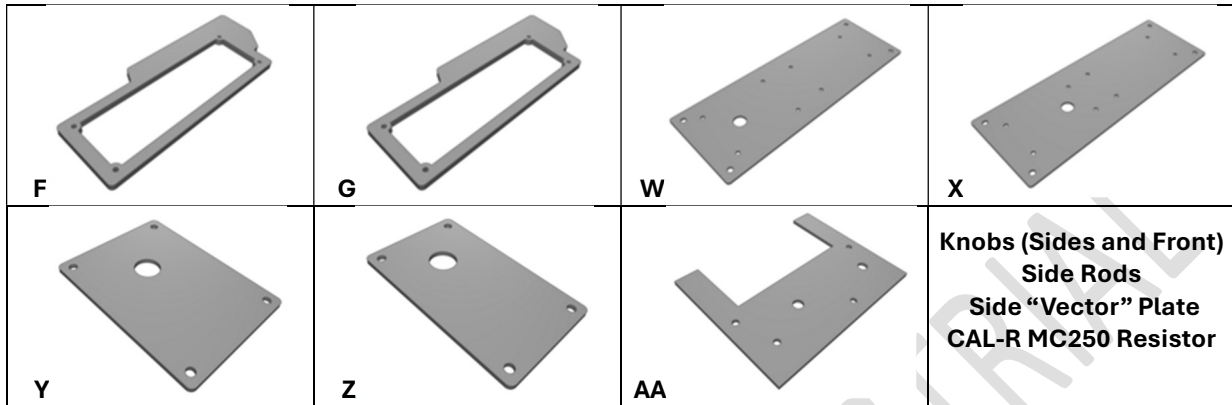

Hardware and Build Materials

- E6000 Glue
- (2) M3x4mm Hex Socket Head Screws (Passivated)
- (6) M3x8mm Hex Socket Head Screws (Passivated)
- (8) M3x6mm Hex Socket Head Screws (Passivated)
- (8) M4x14mm Hex Cap Head Screws (Passivated)
- (12) M3 Nuts (Stainless Steel)

Steps

1. Sand and file burrs on **Parts F, G, W, X, Y, and Z**.
OPTIONAL. Paint **Parts F and G** and polish and coat **Parts W, X, Y, and Z**.

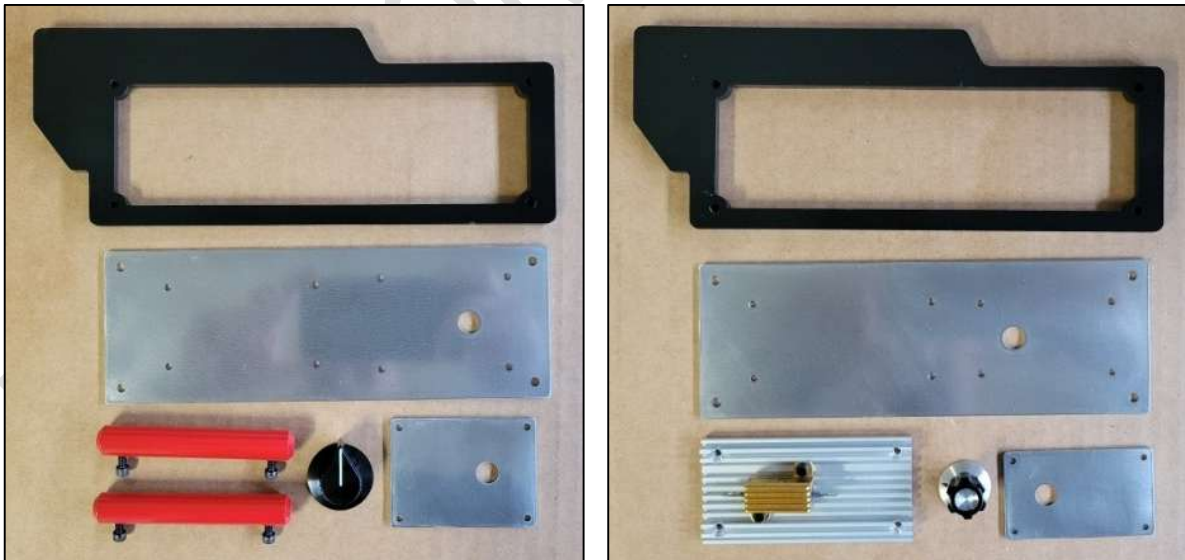

2. Drill 3mm holes through the **Vector Plate** to match the hole placement on **Part X** and carefully drill larger holes on the raised ridges of the vector plate to ensure the socket head screws inset flush. Attach the **CAL-R MC250 Resistor** to the vector plate with E6000 glue and drill 3mm holes through the vector plate using the resistor tabs as a guide. Glue two M3x4mm Hex Socket Head Screws (Passivated) into the holes for aesthetics.

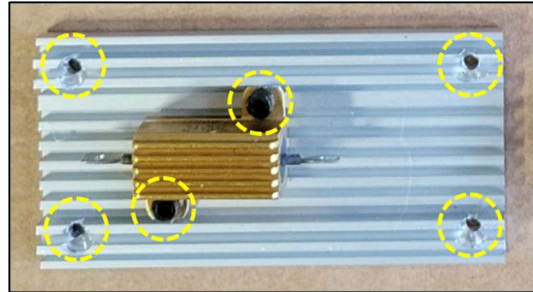

3. Assemble the side panel with the vector plate. Attach the vector plate to the large side panel (**Part X**) with four M3x8mm Hex Socket Head Screws (Passivated) and M3 Nuts (Stainless Steel). Attach the small knob panel (**Part Z**) to **Part X** with four M3x6mm Hex Socket Head Screws (Passivated) and M3 Nuts (Stainless Steel).

Depending on the knob, find a flat head screw of appropriate length to use as a shaft, countersink the reverse side of **Part X** and firmly affix the knob with glue or set screws.

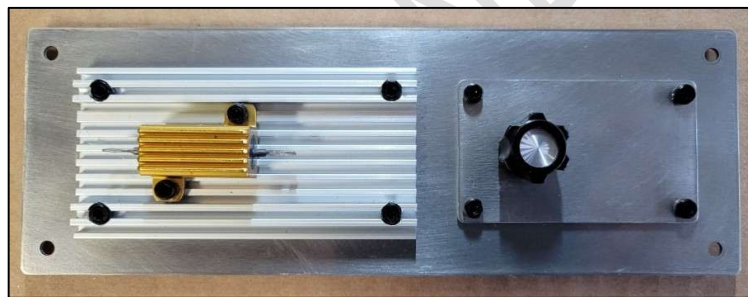

4. Attach the side panel assembly to **Part F** with four M4x14mm Hex Cap Head Screws (Passivated).

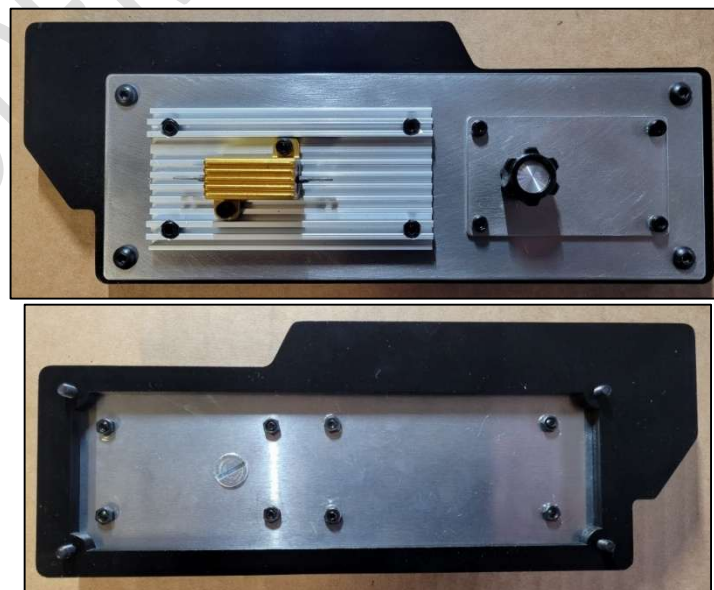

5. Assemble the side panel with the **Side Rods**. Attach the rods to the large side panel (**Part W**) with screws provided with the side rods (the holes in **Part W** may need to be drilled slightly larger to accommodate them). Attach the small knob panel (**Part Y**) to **Part W** with four M3x6mm Hex Socket Head Screws (Passivated) and M3 Nuts (Stainless Steel).
Depending on the knob, find a flat head screw of the appropriate length to use as a shaft, countersink the reverse side of **Part X** and firmly affix the knob with glue or set screws.

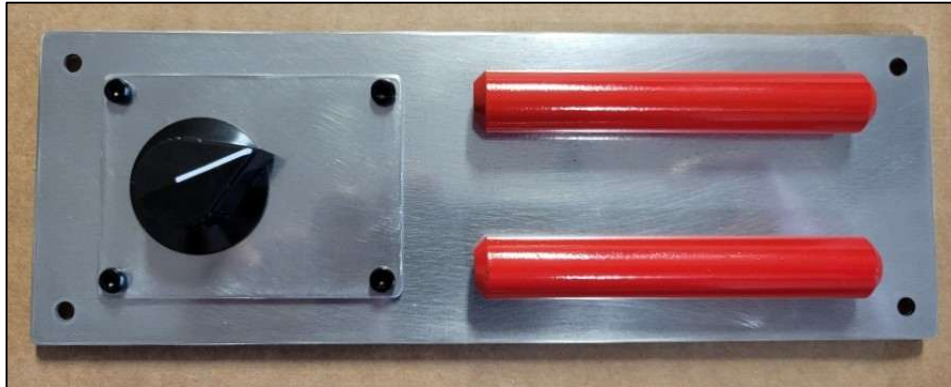

6. Attach the side panel assembly to **Part G** with four M4x14mm Hex Cap Head Screws (Passivated).



7. Sand and file burrs on **Part AA**.
OPTIONAL. Polish and coat **Part AA**.

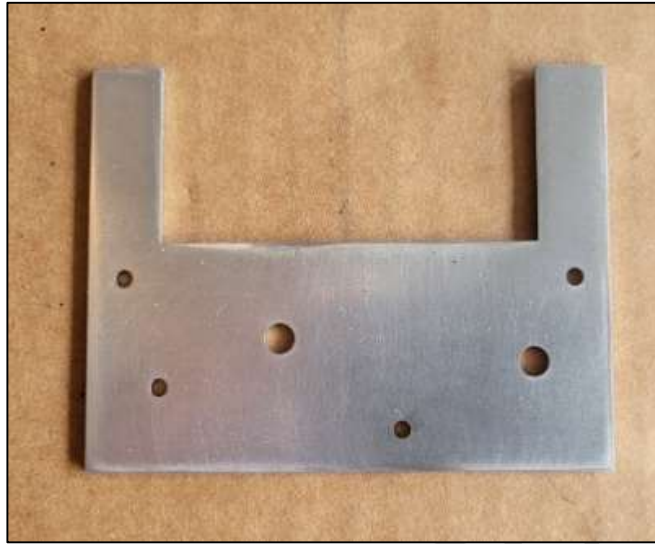

8. Countersink the back side of **Part AA** and attach desired knobs. Ensure two M3x8mm Hex Socket Head Screws (Passivated) fit in the mounting holes.

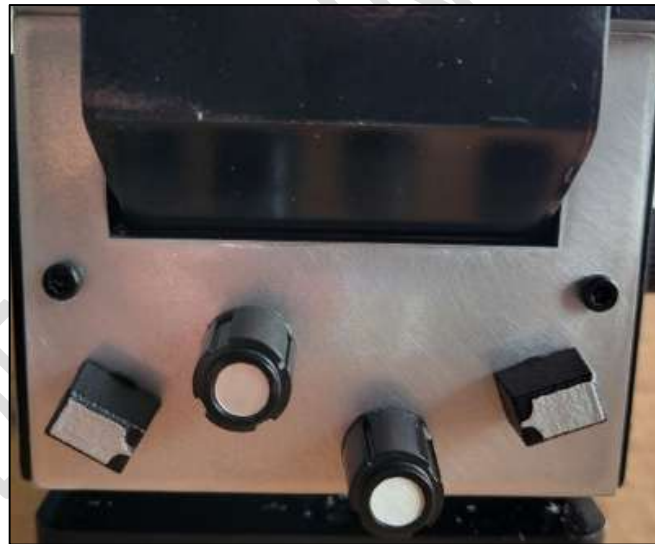

Part 13: Attach Side and Front Panels

Parts

Assembled Trap (Part 11)	Side and Front Panels (Part 12)
-------------------------------------	--

Hardware and Build Materials

- None

Steps

1. Attach the assembled “vector plate” side panel to the trap assembly. Firmly screw in the four M4x14mm Hex Cap Head Screws (Passivated). Do not overtighten.

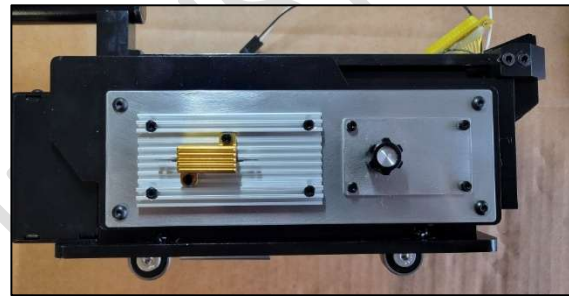
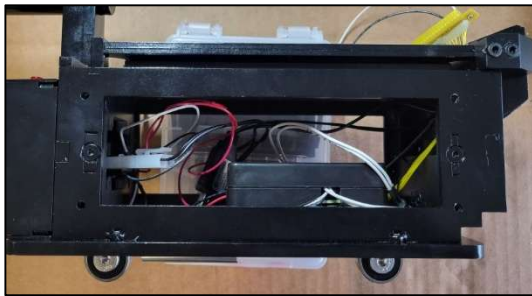

2. Attach the assembled “side rods” side panel to the trap assembly. Firmly screw in the four M4x14mm Hex Cap Head Screws (Passivated). Do not overtighten.



3. Ensure the side panels fit flush, especially where the panels overlap the battery box.

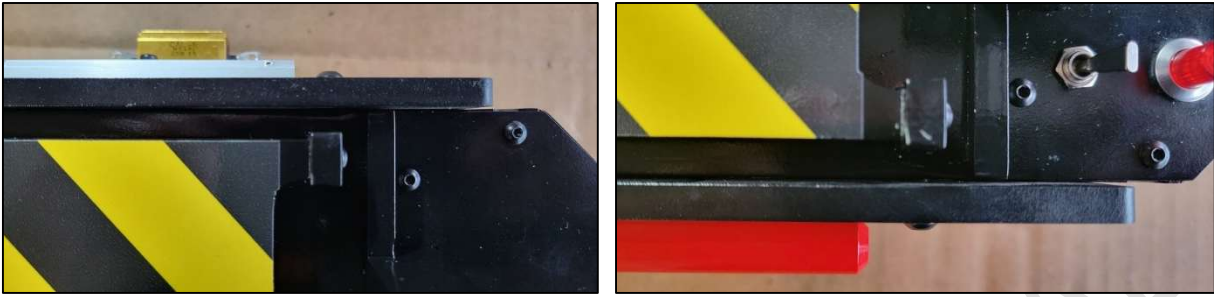

4. Attach the assembled front panel to the trap assembly. Firmly screw in the two M6x8mm Hex Socket Head Screws (Passivated) and ensure the plate fits flushly to the frame. The shrews should thread into the trap assembly but use glue to hold in place if necessary.

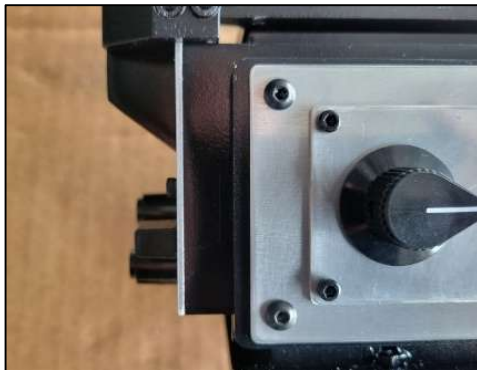
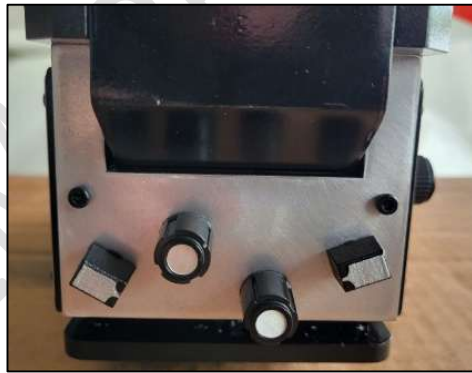

Part 14: Attach LED Box Face Plate

Parts



Hardware and Build Materials

- (4) M3x6mm Hex Socket Head Screws (Passivated)

Steps

1. Affix any electronics into the Segmented LED Box before attaching the face plate (**Part BB**).



2. Affix the LED face plate (**Part BB**) to the Segmented LED Box with four M3x6mm Hex Socket Head Screws (Passivated). The screws should thread into the holes of the Segmented LED Box but use glue to hold in place if necessary.

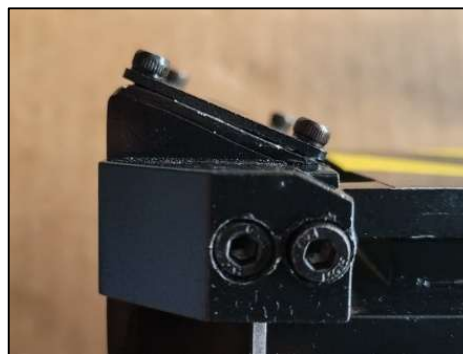
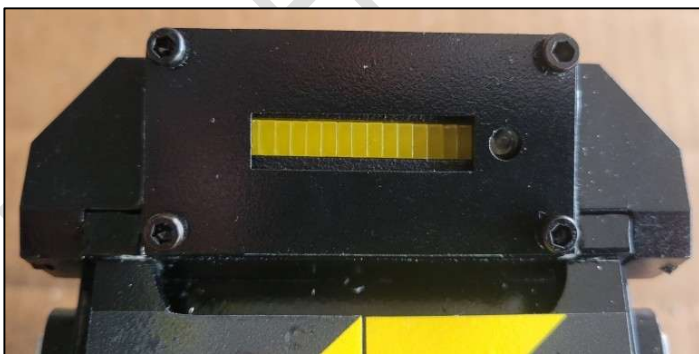

Part 15: Apply Decals

Parts

Assembled Trap from
Part 14

Hardware and Build Materials

- Decals

Steps

1. Apply desired decals to the finished trap.



Finished Ghost Trap Images

